

DATE	Ray <h1>THARP CABINET ORDER</h1>		FRAMES
JOB #			
Sheet 1 of 9			
Description Pilkington/Hermon		Address 1440 Shelby Dr., Lake Estates, Berthod	
Name Pilkington/Hermon		WOOD: Alder	SOFFIT none
Phone 303-570-0572		STAIN: Golden Pecan	DOOR STYLE
Contact John		EDGE:	HINGE: Custom 1 1/4
UPPERS: 42	TOPS: granite 3 mm	FLOORS: 3/4 wood	

provide sub deck

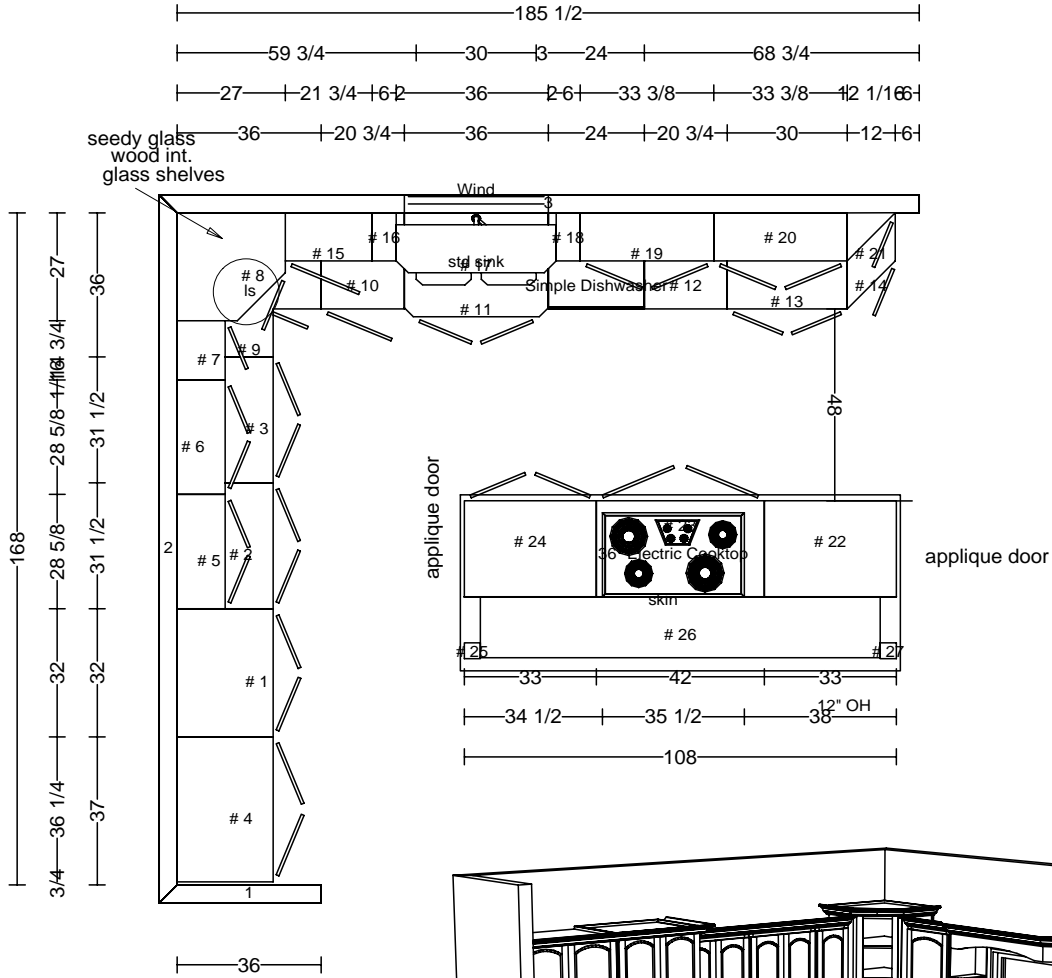

DATE	<h1>THARP CABINET ORDER</h1>		FRAMES
JOB #			
Sheet 2 of 9			
Description Pilkington/Hermon		Address 1440 Shelby Dr., Lake Estates, Berthod	
Name Pilkington/Hermon		WOOD:	SOFFIT
Phone 303-570-0572		STAIN:	DOOR STYLE
Contact John		EDGE:	HINGE:
UPPERS:	TOPS:	FLOORS:	

3/4 — 36 1/4 — | — 32 — | — 28 5/8 — | — 28 5/8 — | — 30 3/4 — | — 27 — |

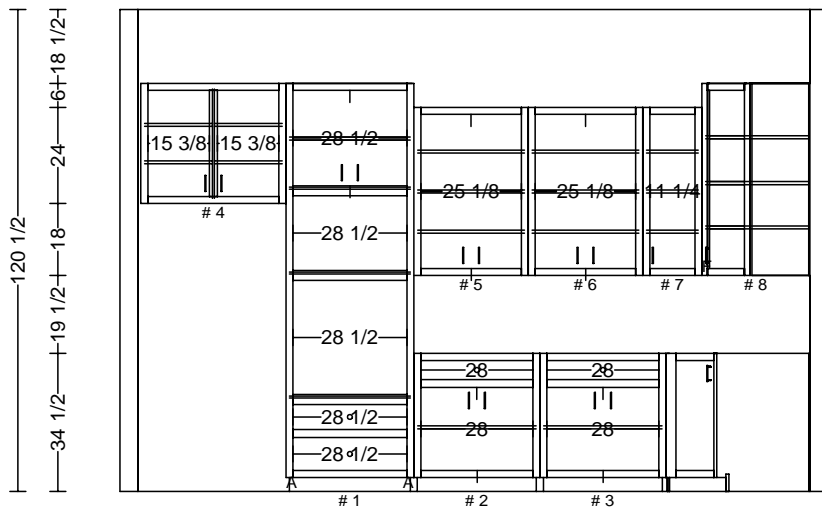

— 37 — | — 32 — | — 31 1/2 — | — 31 1/2 — | — 36 — |
 ————— 168 —————

— 27 — | — 21 3/4 — | — 16 — | — 36 — | — 26 — | — 33 3/8 — | — 33 3/8 — | — 12 1/16 — |

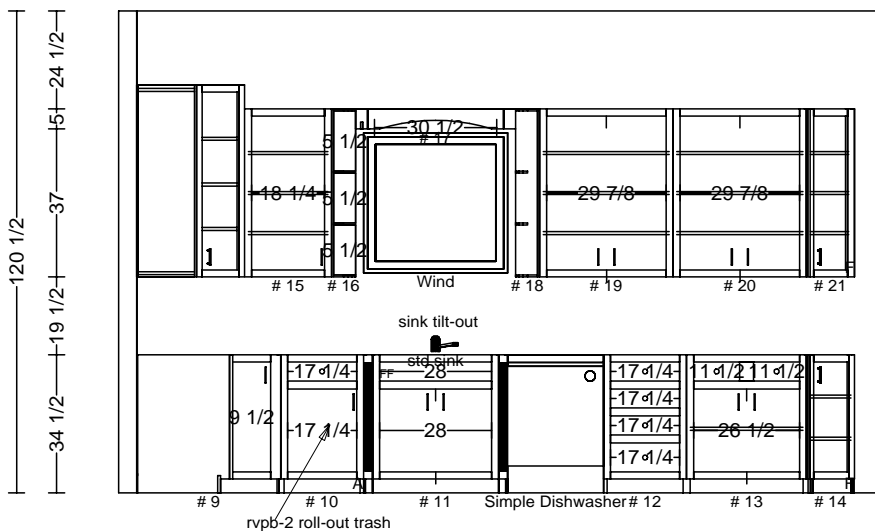

— 36 — | — 20 3/4 — | — 36 — | — 24 — | — 20 3/4 — | — 30 — | — 12 — | — 16 — |
 ————— 185 1/2 —————

DATE	<h1>THARP CABINET ORDER</h1>		FRAMES	
JOB #				
Sheet 3 of 9				
Description Pilkington/Hermon		Address 1440 Shelby Dr., Lake Estates, Berthod		
Name Pilkington/Hermon		WOOD:	SOFFIT	
Phone 303-570-0572		STAIN:	DOOR STYLE	
Contact John		EDGE:	HINGE:	
UPPERS:	TOPS:	FLOORS:		

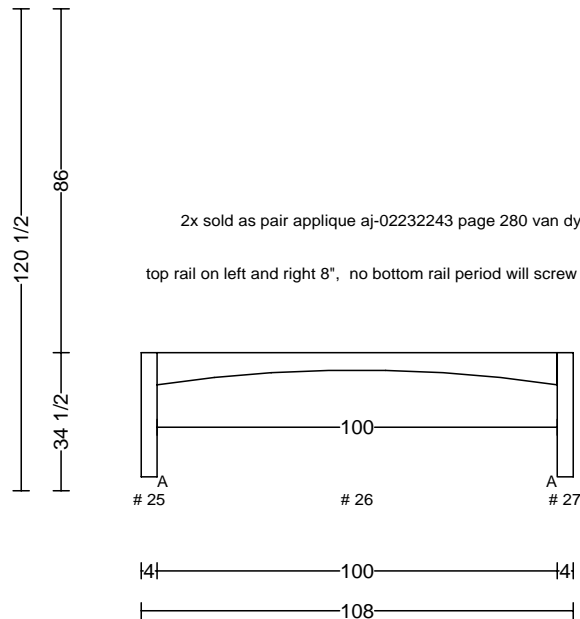
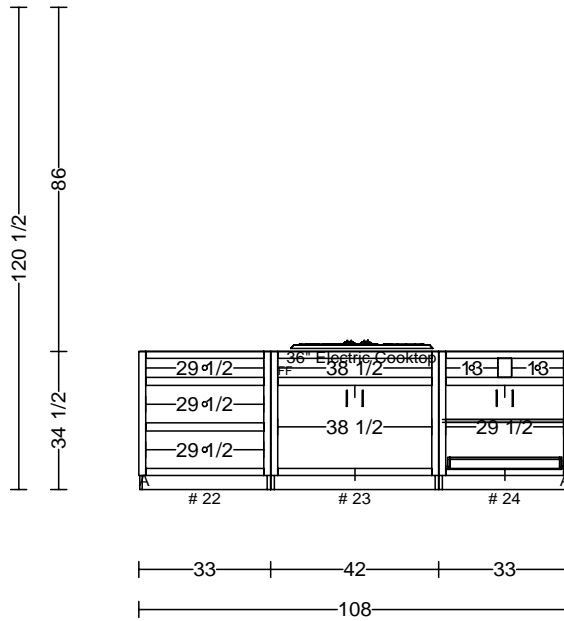

DATE	<h1>THARP CABINET ORDER</h1>		FRAMES
JOB #			
Sheet 4 of 9			
Description Pilkington/Hermon		Address 1440 Shelby Dr., Lake Estates, Berthod	
Name Pilkington/Hermon		WOOD:	SOFFIT
Phone 303-570-0572		STAIN:	DOOR STYLE
Contact John		EDGE:	HINGE:
UPPERS:	TOPS:	FLOORS:	

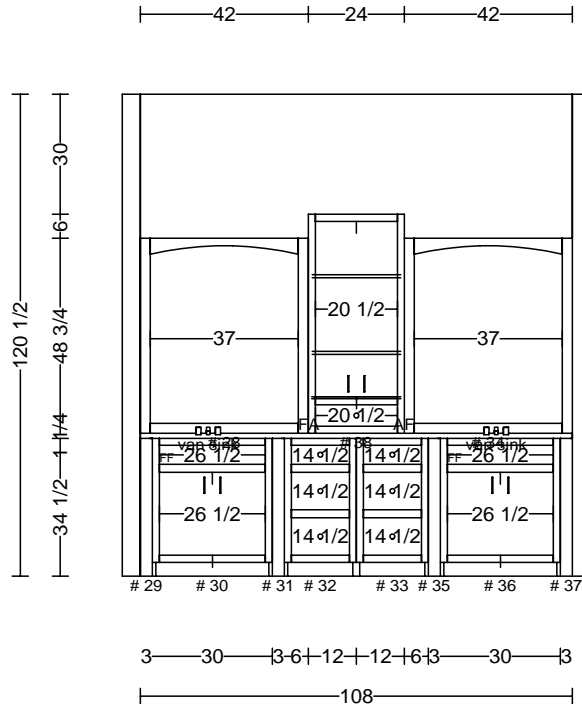
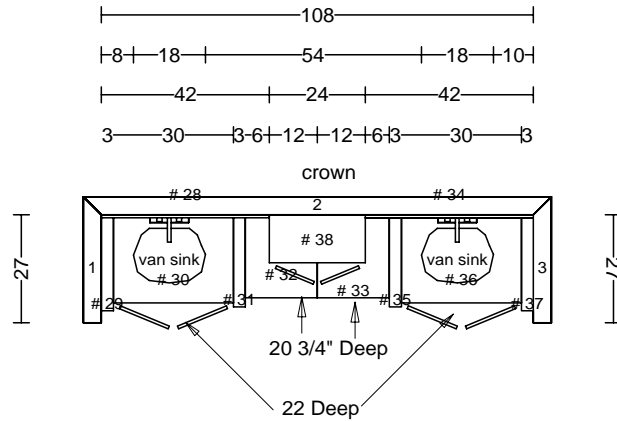

DATE	<h1>THARP CABINET ORDER</h1>		FRAMES	
JOB #				
Sheet 5 of 9				
Description Pilkington/Hermon		Address 1440 Shelby Dr., Lake Estates, Berthod		
Name Pilkington/Hermon		WOOD:	SOFFIT	
Phone 303-570-0572		STAIN:	DOOR STYLE	
Contact John		EDGE:	HINGE:	
UPPERS:	TOPS:	FLOORS:		

provide sub deck

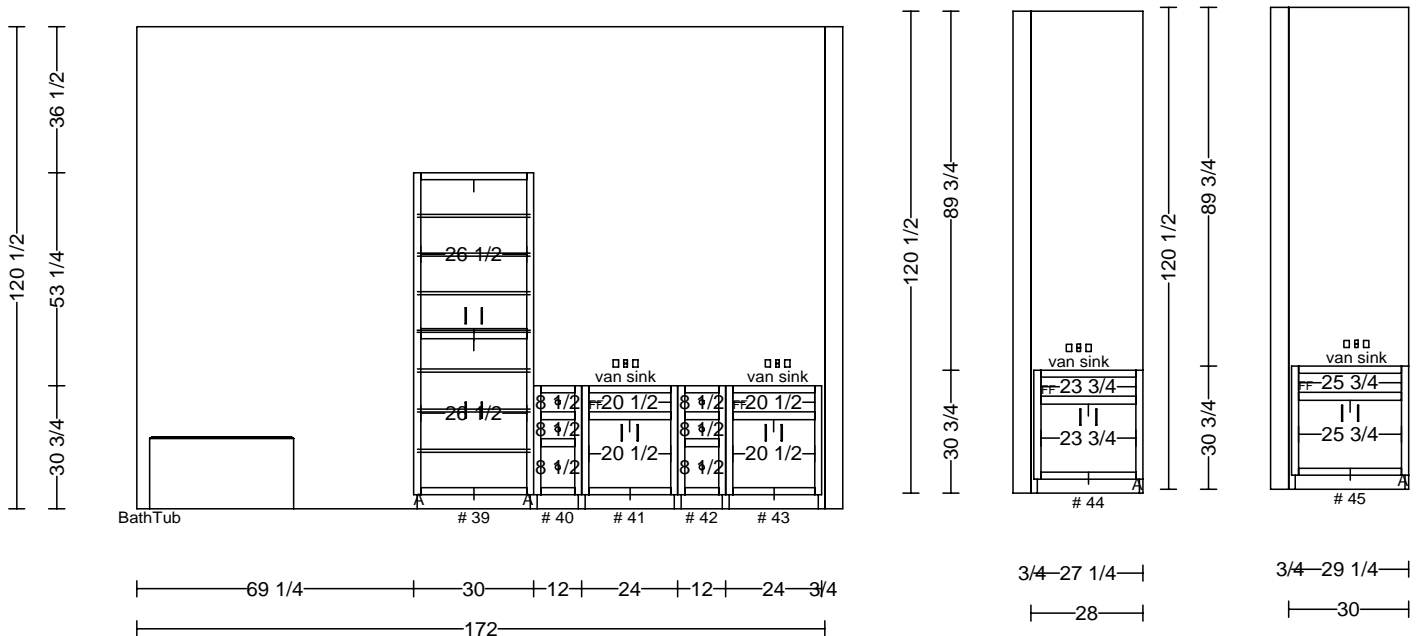
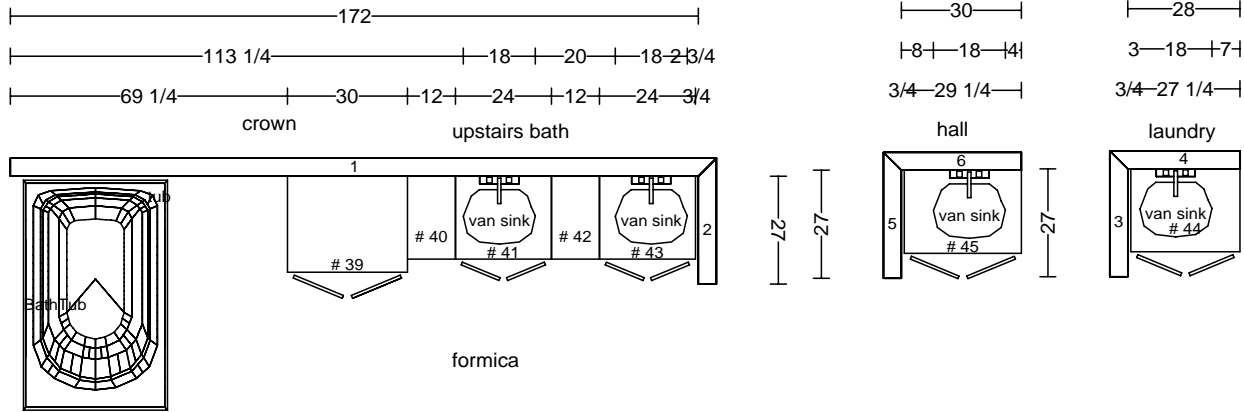

DATE	<h1>THARP CABINET ORDER</h1>	FRAMES	
JOB #			
Sheet 6 of 9			
Description Pilkington/Hermon		Address 1440 Shelby Dr., Lake Estates, Berthod	
Name Pilkington/Hermon		WOOD:	SOFFIT
Phone 303-570-0572		STAIN:	DOOR STYLE
Contact John		EDGE:	HINGE:
UPPERS: 42 & 36	TOPS:	FLOORS:	

provide sub deck

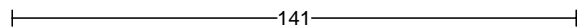
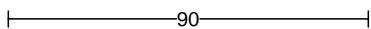
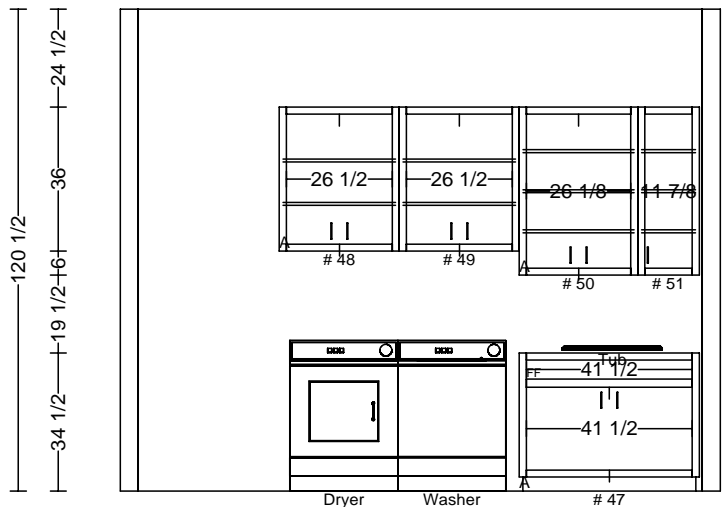
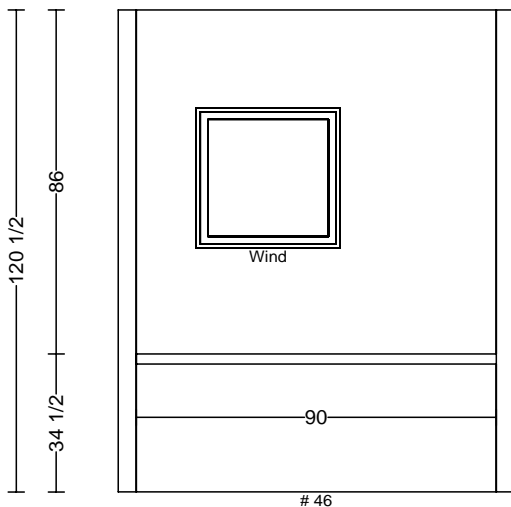
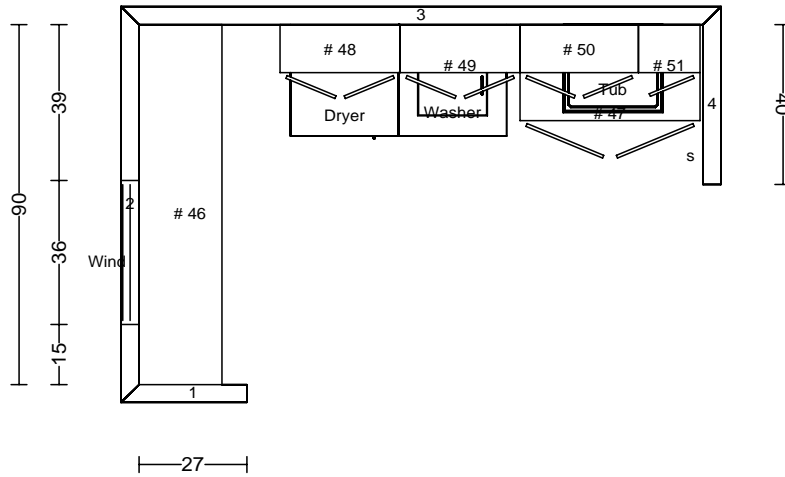
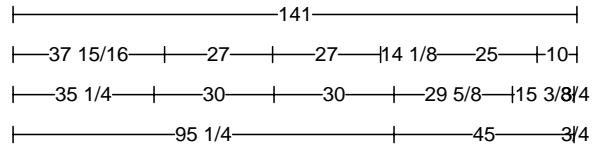

DATE	<h1>THARP CABINET ORDER</h1>		FRAMES
JOB #			
Sheet 7 of 9			
Description Pilkington/Hermon		Address 1440 Shelby Dr., Lake Estates, Berthod	
Name Pilkington/Hermon		WOOD:	SOFFIT
Phone 303-570-0572		STAIN:	DOOR STYLE
Contact John		EDGE:	HINGE:
UPPERS:	TOPS:	FLOORS:	
INSTALL (THARP/SELF):		CUSTOMER PICK-UP (YES/NO):	

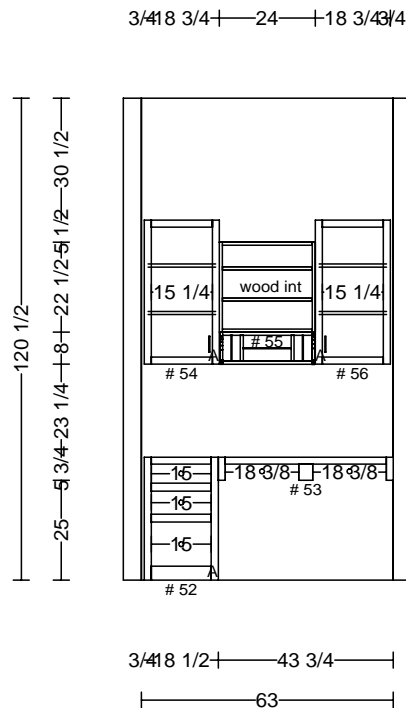
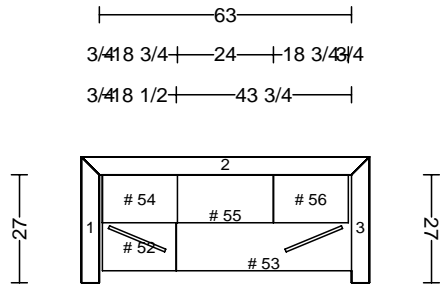

DATE	<h1>THARP CABINET ORDER</h1>		FRAMES
JOB #			
Sheet 8 of 9			
Description Pilkington/Hermon		Address 1440 Shelby Dr., Lake Estates, Berthod	
Name Pilkington/Hermon		WOOD:	SOFFIT
Phone 303-570-0572		STAIN:	DOOR STYLE
Contact John		EDGE:	HINGE:
UPPERS:	TOPS:	FLOORS:	

3/4 18 3/4 | 15 | 18 3/4 3/4

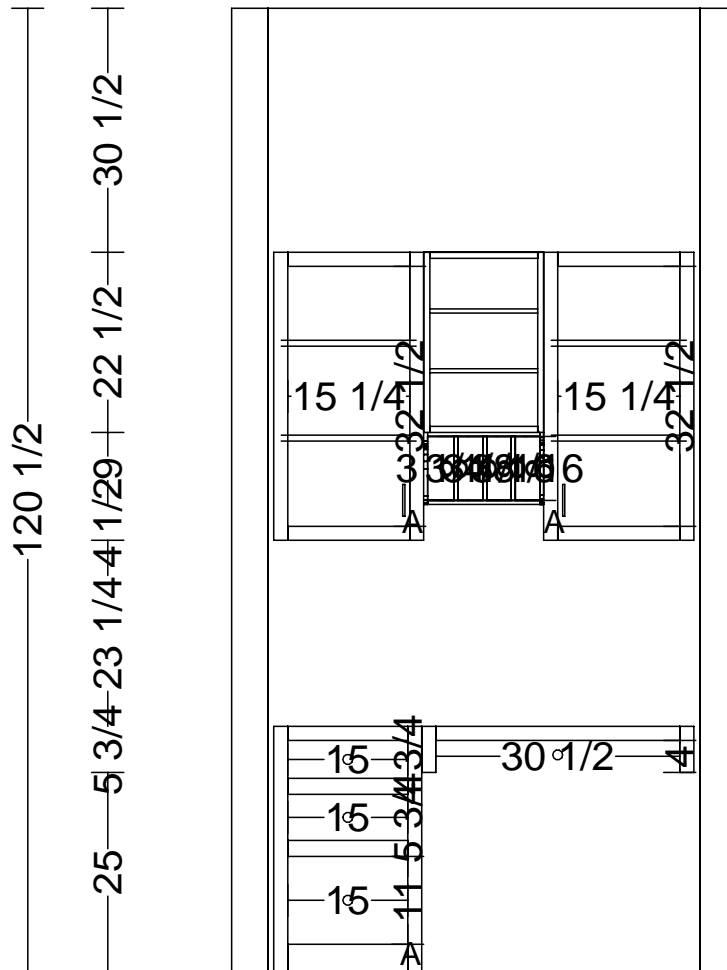

3/4 18 1/2 | 34 | 3/4

54

DATE	<h1>THARP CABINET ORDER</h1>		FRAMES
JOB #			
Sheet 9 of 9			
Description Pilkington/Hermon	Address 1440 Shelby Dr., Lake Estates, Berthod		
Name Pilkington/Hermon	WOOD:	SOFFIT	
Phone 303-570-0572	STAIN:	DOOR STYLE	
Contact John	EDGE:	HINGE:	
UPPERS:	TOPS:	FLOORS:	

